



CSIR-NET, GATE, SET, JEST, IIT-JAM, BARC, TIFR

Contact: 8830156303 | 8329503213

JEST 2026 PAPER

With Answer Key

PHYSICAL SCIENCE

1. For the given Op-Amp circuit, which of the following correctly represents the plot of V_{out} vs V_{in} ?

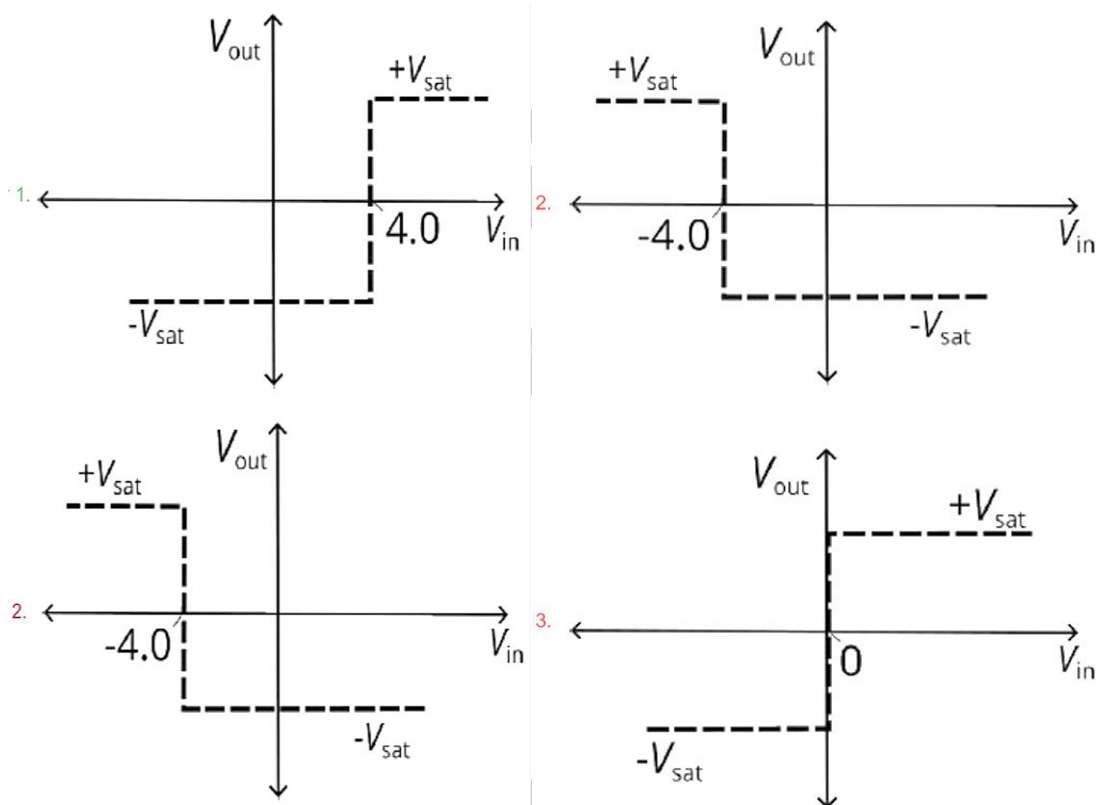
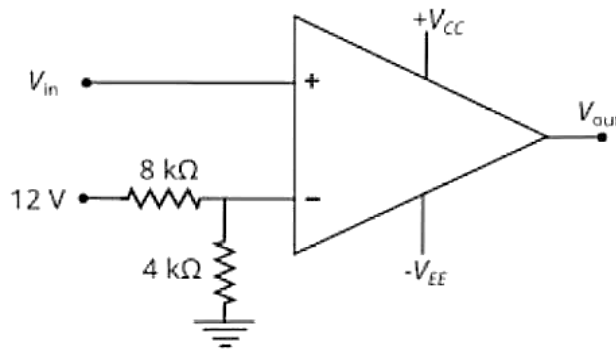

2. The critical volume, pressure and temperature of a van der Waals gas are V_c , P_c , and T_c , respectively. By some means the strength of the attraction between the molecules of the gas is changed. The change in V_c , P_c and T_c are
- (a) $\Delta V_c = 0, \Delta P_c = 0$ and $\Delta T_c = 0$ (b) $\Delta V_c \neq 0, \Delta P_c = 0$ and $\Delta T_c = 0$
(c) $\Delta V_c = 0, \Delta P_c \neq 0$ and $\Delta T_c \neq 0$ (d) $\Delta V_c \neq 0, \Delta P_c \neq 0$ and $\Delta T_c \neq 0$
3. Two charges $+q$ and $-q$ are placed at positions $a\hat{i}$ and $a\hat{j}$. What is the the dipole moment of the system with respect to a point with position vector \vec{r}_0 ?
- (a) $q[a(\hat{i} - \hat{j}) - \vec{r}_0]$ (b) $qa(\hat{i} - \hat{j})$ (c) $\sqrt{2}aq(\hat{i} - \hat{j})$ (d) $q[a(\hat{i} - \hat{j}) + \vec{r}_0]$
4. The internal energy of a gas in a cubical container of length L is proportional to L^{-2} . Which power law does the pressure follow?

- (a) L^{-5} (b) L^{-4} (c) L^{-3} (d) L^{-2}

5. The equation of a closed surface in the lab frame is

$$16x^2 + 25y^2 + 25z^2 = 25$$

An observer moving along the x -axis perceives the closed surface as a sphere of unit radius. If c is the speed of light in vacuum, what is the speed of the observer in the lab frame?

- (a) $\frac{4}{5}c$ (b) $\frac{16}{25}c$ (c) $\frac{9}{25}c$ (d) $\frac{3}{5}c$

6. The vector \vec{B} is defined as $\vec{B} = B_1 f(x)(\sin(ay)\hat{i} + \cos(ay)\hat{j}) + 2B_2 a^2 xy\hat{k}$ where a, B_1 and B_2 are constants with appropriate dimensions. For which of the following forms of the function $f(x)$ will \vec{B} be a valid magnetic field?

- (a) $\ln(ax)$ (b) e^{ax} (c) ax (d) $\sin(ax)$

7. An electromagnetic wave of angular frequency ω is propagating in a dispersive medium with refractive index $n \equiv n(\omega)$. If the speed of light in vacuum is c , the group velocity of the electromagnetic wave in the dispersive medium is

- (a) $\frac{c\omega \frac{dn}{d\omega}}{1 + \frac{\omega}{n} \frac{dn}{d\omega}}$ (b) $\frac{cn}{1 + \frac{\omega}{n} \frac{dn}{d\omega}}$ (c) $\frac{c}{1 + \frac{n}{\omega} \frac{d\omega}{dn}}$ (d) $\frac{c}{n + \omega \frac{dn}{d\omega}}$

8. Let \hat{A} and \hat{B} be two operators. Consider the operator $\hat{C} = [\hat{A} + \hat{A}^\dagger, \hat{B}\hat{B}^\dagger]$, where $[\hat{x}, \hat{y}]$ represents the commutator between the operators \hat{x} and \hat{y} . Which of the following statements about C is true?

- (a) \hat{C} is always Hermitian.
 (b) \hat{C} is Hermitian if \hat{A} is Hermitian and \hat{B} is anti-Hermitian.
 (c) \hat{C} is Hermitian if both \hat{A} and \hat{B} are Hermitian.
 (d) \hat{C} is anti-Hermitian.

9. For two Pauli matrices σ_1, σ_2 , what is the value of the expression

$$\text{Determinant}(\sigma_1^{7641}) - \text{Trace}(\sigma_2^{7641})?$$

The Pauli matrices are given as:

$$\sigma_1 = \begin{pmatrix} 0 & 1 \\ 1 & 0 \end{pmatrix}, \sigma_2 = \begin{pmatrix} 0 & -i \\ i & 0 \end{pmatrix}$$

- (a) 1 (b) -1 (c) 11 (d) -11

10. A detector has a 80% particle detection efficiency. If, in a given time, 10 particles pass through the detector, what is the probability that exactly 9 particles are detected?

- (a) $2 \times (0.8)^9$ (b) $(0.8)^{10}$ (c) $0.2 \times (0.8)^9$ (d) $(0.8)^9$

11. The potential on the surface of a spherical region of unit radius in vacuum is $V(\theta) = [2\cos^2(\theta/2) + \cos^2 \theta]V_0$, where V_0 is a constant. The electrostatic potential in the region, $r \leq 1$ unit is

- (a) $\left(\frac{3-r^2}{2} + r\cos \theta + r^2\cos^2 \theta\right)V_0$ (b) $\left(\frac{3+r^2}{4} + r\cos \theta + r^2\cos^2 \theta\right)V_0$
(c) $\left(\frac{2+r^2}{3} + r\cos \theta + r^2\cos^2 \theta\right)V_0$ (d) $\left(\frac{4-r^2}{3} + r\cos \theta + r^2\cos^2 \theta\right)V_0$

12. In Young's double slit set-up, the screen is placed at a distance $D = 150 \text{ cm}$ from the slits. At a point P on the screen, the second maximum is being observed. What is the minimum amount by which D needs to be changed such that the point P is now at a minimum?

- (a) 20cm (b) 50 cm (c) 30 cm (d) 80 cm

13. Consider a system of a large even number of hard identical particles confined within a length L in one dimension which is bounded by two reflecting hard boundaries. At time $t = 0$, half of these particles have velocity $+v$ and the other half has velocity $-v$ distributed randomly among them. Assuming that all collisions are elastic, which one of the following statements is correct?

- (a) The velocity distribution of the system remains unchanged in all future times.
(b) The velocity distribution changes later from the initial distribution but it never becomes the Maxwell-distribution.
(c) The velocity distribution of the system becomes the Maxwell-distribution at the time $t \sim L/v$.
(d) The velocity distribution of the system becomes the Maxwell-distribution within the time $t < L/v$.

14. Which of the following Hamiltonians correctly represents a one-dimensional simple harmonic oscillator of mass m , frequency ω and minimum of the potential at $x = a$?

- (a) $\mathcal{H} = -\frac{\hbar^2}{2}m\omega^2 \frac{\partial^2}{\partial p^2} + \frac{p^2}{2m} + \frac{1}{2}m\omega^2 a^2 + i\hbar m\omega^2 a \frac{\partial}{\partial p}$
(b) $\mathcal{H} = -\frac{\hbar^2}{2m} \frac{\partial^2}{\partial p^2} + \frac{1}{2}m\omega^2(p - a)^2$

$$(c) \mathcal{H} = -\frac{\hbar^2}{2} m\omega^2 \frac{\partial^2}{\partial p^2} + \frac{p^2}{2m} + \frac{1}{2} m\omega^2 a^2$$

$$(d) \mathcal{H} = -\frac{\hbar^2}{2} m\omega^2 \frac{\partial^2}{\partial p^2} + \frac{p^2}{2m} + \frac{1}{2} m\omega^2 a^2 - i\hbar m\omega^2 a \frac{\partial}{\partial p}$$

15. Consider a polarized dielectric sphere with the polarization given as $P(r) = P_0 r i$, where r is the distance from the centre of the sphere and P_0 is a constant. The bound charge density at a point (r, θ, ϕ) inside the sphere is

$$(a) -P_0 \sin \theta \cos \phi$$

$$(b) P_0 \cos \theta \cos \phi$$

$$(c) -P_0 \cos \theta \sin \phi$$

$$(d) P_0 \sin \theta \cos \phi$$

16. There are N non-interacting magnetic moments of unit strength, fixed at certain positions in free space. These moments are subjected to a constant magnetic field $B = Bk$ and the temperature of the system is T . If k_B is the Boltzmann constant, the Helmholtz free energy F of the system is

$$(a) -Nk_B T \left[\ln \left(2 \sinh \frac{B}{k_B T} \right) - \ln \left(\frac{B}{k_B T} \right) \right] \quad (b) Nk_B T \left[\ln \left(2 \sinh \frac{B}{k_B T} \right) - \ln \left(\frac{B}{k_B T} \right) \right]$$

$$(c) -Nk_B T \left[\ln \left(2 \sinh \frac{B}{k_B T} \right) + \ln \left(\frac{B}{k_B T} \right) \right] \quad (d) Nk_B T \left[\ln \left(2 \sinh \frac{B}{k_B T} \right) + \ln \left(\frac{B}{k_B T} \right) \right]$$

17. What is $\left\langle \frac{1}{r} \right\rangle$ in the state $|n, l, m\rangle$ of a hydrogen atom in terms of the Bohr radius a_0 ?

$$(a) \frac{1}{n^2 a_0}$$

$$(b) \frac{1}{2n^2 a_0}$$

$$(c) \frac{1}{2n a_0}$$

$$(d) \frac{1}{4n^2 a_0}$$

18. An infinite material has electrons moving freely in the background of fixed positive charges. Initially the average charge density of electrons (ρ^-) and that of the positive charges (ρ^+), satisfy $\rho^+ = -\rho^- = \rho_0$. What is the average net charge density of the material if an electric field \vec{E} is turned on resulting in a steady velocity \vec{u} of the electrons throughout the material? c is the speed of light.

$$(a) 0 \quad (b) \rho_0 \left(1 - \frac{1}{\sqrt{1 - u^2/c^2}} \right)$$

$$(c) \rho_0 \left(\frac{1}{\sqrt{1 - u^2/c^2}} - 1 \right) \quad (d) \rho_0 \left(1 - \frac{1}{(1 - u^2/c^2)^{3/2}} \right)$$

19. An operator A is expressed in terms of angular momentum operators as:

$$A = L^2 + aL_z^2 + b(L_+L_- + L_-L_+)$$

where $L_{\pm} = L_x \pm iL_y$ and a, b are arbitrary constants. Under what condition does A commute with L_x^2 ?

- (a) $2a = b$ (b) $a = 2b$ (c) $a = -b$ (d) $a = b$

20. Consider the solution of the differential equation $y'' + 2xy' + \lambda y = 0$ around $x = 0$. For which of the following values of λ is the solution a polynomial?

- (a) -3 (b) 2.1 (c) -2 (d) 2

21. A satellite is orbiting in an elliptical orbit of non-zero eccentricity about a massive planet of mass M .

If the angular speed of the satellite is ω_* at the point of closest distance a from the planet (where $\dot{r} = 0$ and $\ddot{r} > 0$), which of the following relations is true? G is the Gravitational constant.

- (a) $a\omega_*^2 > \frac{GM}{a^2}$ (b) $a\omega_*^2 = \frac{GM}{a^2}$ (c) $a\omega_*^2 < \frac{GM}{a^2}$ (d) $a\omega_*^2 = \frac{GM}{2a^2}$

22. The Lagrangian of a particle of unit mass is given by $L = -\sqrt{1 - (dx/dt)^2} - \alpha x$, where α is a constant. The trajectory of the particle in the phase space is :

- (a) a hyperbola (b) a circle (c) an ellipse (d) a straight line

23. What is the general solution of the equation $\frac{df(t)}{dt} = f(t) + 6 \int f(t) dt$?

- (a) $f(t) = Ae^{-2t} + Be^{3t}$ (b) $f(t) = Ae^{2t} + Be^{-3t}$
(c) $f(t) = Ae^{-2t} + Be^{-3t}$ (d) $f(t) = Ae^{2t} + Be^{3t}$

24. In an electro-dynamical set-up, a gauge transformation takes the vector potential \vec{A} to $\vec{A} + \vec{\nabla}f$ where $f = \alpha x^2 t^2$ with a positive constant α . Which of the following statements is correct about the electric field (\vec{E}) and scalar potential ϕ at $(t, x, y, z) = (-1, 1, 0, 0)$?

- (a) Both \vec{E} and ϕ increase. (b) \vec{E} remains same and ϕ increases.
(c) Both \vec{E} and ϕ remain same. (d) \vec{E} remains same and ϕ decreases.

25. A particle subject to the one-dimensional infinite square well potential

$$V(x) = \begin{cases} 0, & \text{if } 0 \leq x \leq a \\ \infty & \text{otherwise} \end{cases}$$

is initially in the state

$$\psi(x) = \begin{cases} Ax(a-x), & \text{if } 0 \leq x \leq a \\ 0 & \text{otherwise} \end{cases}$$

where A and a are constants. Let $P_1(t)$ be the probability that a measurement of the energy of the particle at time t yields the outcome $E_1 = \frac{\pi^2 \hbar^2}{2ma^2}$. Which of the following is true for time $t > 0$?

$$(a) P_1(t) \propto \exp \left\{ -\frac{\pi^2 \hbar}{2ma^2} t \right\}$$

$$(b) P_1(t) \propto 1 - \exp \left\{ -\frac{\pi^2 \hbar}{2ma^2} t \right\}$$

(c) $P_1(t)$ is independent of time

(d) $P_1(t) \propto t^2$

26. Two identical bosons in a one-dimensional harmonic oscillator potential (with angular frequency ω) have total energy $E = 100\hbar\omega$. What is the entropy of this state if k_B is the Boltzmann constant?

(a) $k_B \ln(50)$

(b) $k_B \ln(99)$

(c) $k_B \ln(198)$

(d) $k_B \ln(100)$

27. A circular ring of radius R with a line charge density $\lambda = \lambda_0 \cos \phi$ lies on the $x - y$ plane centered at the origin. What is the approximate work done in bringing a unit positive test charge from infinity to the point (r, θ, ϕ) when $r/R \gg 1$?

$$(a) \frac{\lambda_0 R^2}{4\epsilon_0 r^2} \sin \theta \cos \phi$$

$$(b) \frac{\lambda_0 R^2}{4\epsilon_0 r^2}$$

$$(c) \frac{\lambda_0 R^2}{4\epsilon_0 r^2} \cos \phi$$

$$(d) \frac{\lambda_0 R^2}{4\epsilon_0 r^2} \cos \theta \cos \phi$$

28. What is the value of the integral $\int_0^\infty \frac{k \sin(kr)}{k^2 + m^2} dk$ for $r > 0$?

$$(a) \frac{1}{4\pi r} e^{-mr}$$

$$(b) \frac{\pi r}{1 + m^2 r^2}$$

$$(c) \frac{1}{r\sqrt{1 + m^2 r^2}}$$

$$(d) \frac{\pi}{2} e^{-mr}$$

29. Consider the Op Amp circuit with a sinusoidal voltage input. What is the correct output waveform of this circuit?

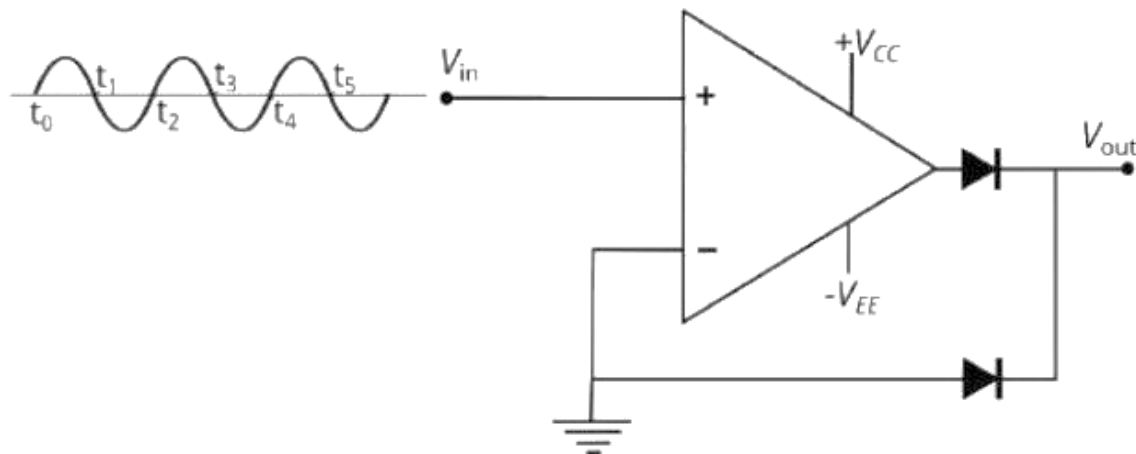

(a)

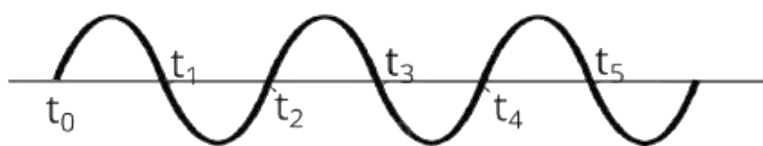

(b)

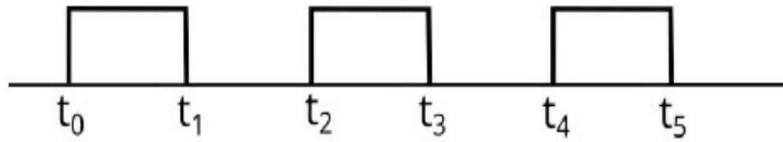

(c)

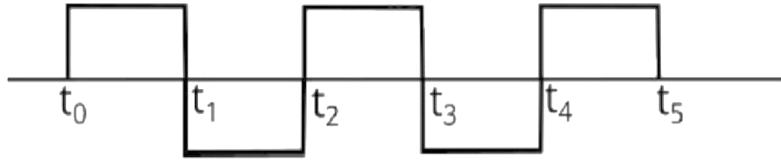

(d)

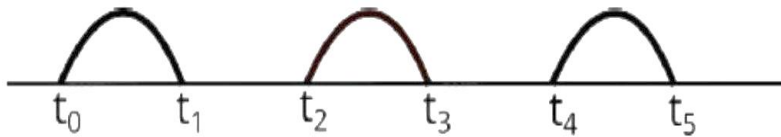

30. Consider a state $|\lambda\rangle = e^{\lambda a^\dagger} |0\rangle$ defined in a one-dimensional harmonic oscillator such that $a|\lambda\rangle = \lambda|\lambda\rangle$. Here a and a^\dagger are the annihilation and creation operators respectively and $|0\rangle$ is the ground state. What is $\langle\lambda_1 | \lambda_2\rangle$?

(a) 0

(b) $e^{\lambda_1^* \lambda_2}$

(c) $e^{\lambda_1^* + \lambda_2}$

(d) $\delta(\lambda_1 - \lambda_2)$ (complex δ -function)

31. Consider the action $S = \int_0^2 [(dx/dt)^2 + 6x] dt$. If the boundary conditions are such that $x(0) = 0$, and $x(2) = 6$, what is the value of the action evaluated on the extremal path?

32. Consider a Newton's rings experiment with a biconvex lens of diameter 20 cm and maximum thickness $60 \mu\text{m}$ placed on a flat reflecting surface, illuminated by normal incident light of wavelength 600 nm. When we change the medium of the experiment from air to a liquid medium, the fringe separation reduces by 20%. What the refractive index of the liquid medium?

33. A system of two spin-1/2 particles is in the state $|\uparrow\downarrow\rangle$ for time $t < 0$. At $t = 0$, an interaction Hamiltonian $\hat{H} = C \hat{\mathbf{S}}^{(1)} \cdot \hat{\mathbf{S}}^{(2)}$ is turned on, where C is a constant of the appropriate dimension and $\hat{\mathbf{S}}^{(1)}$ and $\hat{\mathbf{S}}^{(2)}$ are the spin angular momentum operators of the first and second particle respectively. What is the probability in percentage to find the system in the state $|\downarrow\uparrow\rangle$ at time $t = \frac{2\pi}{3C\hbar}$?

34. In a two-dimensional Hilbert space, two Hermitian non-commuting operators A and B have nondegenerate normalized eigenstates, which satisfy $A|\psi_A^i\rangle = a_i|\psi_A^i\rangle$ and $B|\psi_B^i\rangle = b_i|\psi_B^i\rangle$ where $i = 1, 2$.

The relations:

$$|\psi_A^1\rangle = \frac{1}{\sqrt{5}}|\psi_B^1\rangle + \frac{2}{\sqrt{5}}|\psi_B^2\rangle; |\psi_B^1\rangle = \frac{1}{\sqrt{5}}|\psi_A^1\rangle - \frac{2}{\sqrt{5}}|\psi_A^2\rangle$$

are given. After a measurement of B is done on the state $|\psi_A^2\rangle$, what is the percentage probability of finding the system in the state $|\psi_A^1\rangle$?

35. A diagnostic test for a particular disease detects it with an efficiency of 99.99% in infected people. It also detects a false positive result in 0.02% of people who are not infected. If one person in 10000 in the general population is infected, what is the probability (in nearest integer percent) that someone who tests positive is actually infected?
36. Three planets are orbiting a star S_* in coplanar circular orbits of radii $R, 4R$ and $9R$. The time period of the planet closest to the star is 1 year. At some instant the star and the planets are collinear. Ignoring the motion of the star, after how many years will the same aligned configuration of the planets occur again?
37. Two concentric conducting spheres of radii 4 m and 5 m respectively, enclose a medium of conductivity σ (in units of $m^{-1}\Omega^{-1}$) between their surfaces. The potential difference between the surfaces of the spheres is maintained at V (in volts). In this setup, there will be a current I (in amperes) between the spheres. What is the characteristic length scale $I/(4\pi\sigma V)$ of the system in metres?
38. A particle of mass m_0 is initially at rest in an inertial frame and is subjected to a constant force m_0g along the y -axis. Its motion is governed by the equation:

$$\frac{dp}{dt} = m_0g$$

where p is the relativistic momentum. If $y(t)$ depicts the distance covered by the particle in time t as $y\left(t = \frac{\sqrt{8}c}{g}\right) = n \frac{c^2}{g}$, where c is the speed of light, what is n ?

39. The Lagrangian of a particle in one dimension is $L = 10\dot{x}^2 + 6\dot{x}t^2 + \alpha xt$ where $\dot{x} \equiv dx/dt$ and α is a constant. The particle starts moving at time $t = 0$ from the position $x(0) = 0.5$ with $\dot{x}(0) = 0.5$ in appropriate units. For what value of α , is the position of the particle at time t given by $x(t) = \frac{t+1}{2}$?
40. Consider the given circuit with $V_{CC} = 10\text{ V}$, $R_B = 1M\Omega$, and $R_C = 10k\Omega$. It is given that $V_{CE} = V_{BE}$, where V_{CE} is the collector-emitter voltage and V_{BE} is the base-emitter junction voltage. What is the gain β of the transistor?

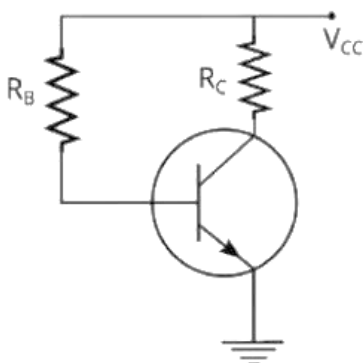

Answer Key

1. a	2. c	3. b	4. a	5. d	6. b	7. d	8. d	9. b	10. a
11. d	12. c	13. a	14. d	15. a	16. a	17. a	18. b	19. b	20. c
21. a	22. a	23. a	24. b	25. c	26. a	27. a	28. d	29. b	30. b
31. 48	32. 1.25	33. 75	34. 32	35. 33	36. 216	37. 20	38. 2	39. 12	40. 100

