



**CSIR-NET, GATE, SET, JEST, IIT-JAM, BARC, TIFR**

Contact: 8830156303 | 8329503213

---

**JEST**

**Question Paper-2020**

**PHYSICAL SCIENCE**

---

1. The persons named  $A, B, C, D, E, F, G, H, I, J$  have come for an interview. They are being called one by one to the interview panel at random. What is the probability that  $C$  gives interview before  $A$  and  $A$  gives before  $F$  ?
- (a)  $\frac{1}{6}$                       (b)  $\frac{1}{10}$
- (c)  $\frac{1}{8}$                       (d)  $\frac{1}{4}$
2. The ratio of maximum to minimum resistance that can be obtained with  $N$  number of  $3 - \Omega$  resistors is
- (a)  $N$                       (b)  $N^2$
- (c)  $N^3$                       (d)  $N^4$
3. Consider three infinitely long, straight and coplanar wires which are placed parallel to each other. The distance between the adjacent wires is  $d$ . Each wire carries a current  $I$  in the same direction. Consider points on either side of the middle wire where the magnetic field vanishes. What is the distance of these points from the middle wire?
- (a)  $\frac{2d}{3}$                       (b)  $\frac{2d}{\sqrt{3}}$
- (c)  $\frac{d}{3}$                       (d)  $\frac{d}{\sqrt{3}}$
4. A rod consists of two equal sections of length  $l$  each with coefficient of thermal conductivity  $\kappa_1$  and  $\kappa_2$ , respectively. One end of the rod is kept at a fixed temperature  $T_1$  and the other end at a temperature  $T_2$  ( $T_1 > T_2$ ). If  $\kappa_2 = 2\kappa_1$  then the temperature at the interface is
- 
- (a)  $T = \frac{(2T_1 - T_2)}{3}$       (b)  $T = \frac{(2T_1 + T_2)}{3}$
- (c)  $T = \frac{(T_1 + 2T_2)}{3}$       (d)  $T = \frac{(T_1 - 2T_2)}{3}$
5. If  $f(t)$  is a real and even function of  $t$ , which one of the following statements is true about

its Fourier transform  $F(\omega)$  (here \* indicates complex conjugation)?

- (a)  $F^*(\omega) = -F(\omega)$
- (b)  $F^*(\omega) = F(\omega)$
- (c)  $F(-\omega) = F(\omega)$
- (d)  $F(-\omega) = F^*(\omega)$
6. Consider an ideal gas whose entropy is given by
- $$S = \frac{n}{2} \left[ \sigma + 5R \ln \frac{U}{n} + 2R \ln \frac{V}{n} \right],$$
- where  $n$  is the number of moles,  $\sigma$  is a constant,  $R$  is the universal gas constant,  $U$  is the internal energy and  $V$  is the volume of the gas. The specific heat at constant pressure is then given by
- (a)  $\frac{5}{2} nR$                       (b)  $\frac{7}{2} nR$
- (c)  $\frac{3}{2} nR$                       (d)  $nR$
7. A 16-bit analog to digital converter works in the range  $0 - 1$  Volt. The least count of the converter is
- (a)  $0.30\text{mV}$                       (b)  $15.26\text{mV}$
- (c)  $5.44\text{nV}$                       (d)  $15.26\mu\text{V}$
8. A particle in a spherically symmetric potential is known to be in an eigenstate of  $\vec{L}^2$  and  $L_2$  with eigenvalues  $1(1+1)\hbar^2$  and  $m\hbar$ , respectively. What is the value of  $\langle 1, m | L_x^2 | 1, m \rangle$  ?
- (a)  $\frac{\hbar^2}{2} (1^2 + 1 + m^2)$
- (b)  $\hbar^2 (1^2 + 1 - m^2)$
- (c)  $\frac{\hbar^2}{2} (1^2 + 1 - m^2)$
- (d)  $\frac{\hbar^2}{2} (1^2 + 1 - m^2)$

9. A particle of mass  $m$  carrying angular momentum  $l$  moves in a central potential  $V(r) = -\frac{ke^{-ar}}{r}$ , where  $k, a$  are positive constants. If the particle undergoes circular motion, what is the equation determining its radius  $r_0$  ?

- (a)  $\frac{l^2}{mr_0} = kar_0e^{-aa_0}$
- (b)  $\frac{l^2}{mr_0} = ke^{-ar_0}(1 + ar_0)$
- (c)  $\frac{l^2}{2mr_0} = ke^{-ar_0}$
- (d)  $\frac{l^2}{2mr_0} = ke^{-ar_0}(1 + ar_0)$

10. Calculate the collector current and determine whether or not the transistor in figure shown below is in saturation. Assume  $V_{CE}(\text{sat}) = 0.2 \text{ V}$

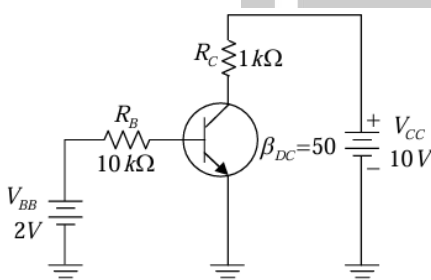

- (a) 6.5 mA, not in saturation
- (b) 11.5 mA, in saturation
- (c) 11.5 mA, not in saturation
- (d) 6.5 mA, in saturation

11. Charges are placed as follows:  $q$  at  $(a, a, 0)$  and  $(-a, -a, 0)$  and  $-q$  at  $(a, -a, 0)$  and  $(-a, a, 0)$ . At large distances, how does the electrostatic potential behave as a function of the distance  $r$  from the centre  $(0,0,0)$  ?

- (a)  $1/r^3$                       (b)  $1/r^2$
- (c)  $1/r$                          (d)  $1/r^4$

12. An  $n \times n$  Hermitian matrix  $A$  is not a multiple of the identity matrix. Which one of the following statements is always true?

- (a)  $n\text{Tr}(A^2) = (\text{Tr} A)^2$
- (b)  $n\text{Tr}(A^2) < (\text{Tr} A)^2$
- (c)  $n\text{Tr}(A^2) > (\text{Tr} A)^2$
- (d)  $\text{Tr}(A^2) = n(\text{Tr} A)^2$

13. A ring of radius 0.5 m has a gap of  $0.002\pi$  m. If the ring carries a charge of  $+1.0 \text{ C}$  distributed uniformly along it, then the electric field at the centre of the ring is

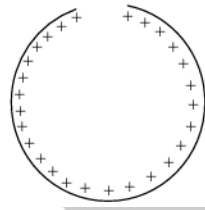

- (a)  $7.5 \times 10^7 \text{ NC}^{-1}$
- (b)  $7.2 \times 10^7 \text{ NC}^{-1}$
- (c)  $6.2 \times 10^7 \text{ NC}^{-1}$
- (d)  $6.5 \times 10^7 \text{ NC}^{-1}$

14. Consider a system of two particles at temperature  $T \rightarrow \infty$ . Each of them can occupy three different quantum energy levels having energies  $0, \epsilon$  and  $2\epsilon$ , and both of them cannot occupy the same energy level. What is the average energy of the system?

- (a)  $\epsilon$                               (b)  $\frac{3\epsilon}{2}$
- (c)  $2\epsilon$                             (d)  $4\epsilon$

15. If  $x$  and  $y$  have the joint probability distribution  $f(x, y) = \frac{3}{4} + xy$  for  $0 < x, y < 1$ , and  $f(x, y) = 0$  otherwise. What is the probability that  $y$  assumes a value greater than  $\frac{1}{2}$ , given that  $x$  is equal to  $\frac{1}{2}$ ?

- (a)  $\frac{6}{16}$                             (b)  $\frac{7}{16}$

- (c)  $\frac{8}{16}$                       (d)  $\frac{9}{16}$

16. The wave function of an electron in one dimension is given by

$$\psi(x) = \begin{cases} 0, & \text{for } x < 0 \\ 2\sqrt{3}e^{-x}(1 - e^{-x}), & \text{for } x \geq 0 \end{cases}$$

The ratio between the expected position  $\langle x \rangle$  and the most probable position  $x_m$  is

- (a) 0.856                      (b) 1.563

- (c) 2.784                      (d) 3.567

17. A particle is to slide along the horizontal circular path on the inner surface of the funnel as shown in the figure. The surface of the funnel is frictionless. What must be the speed of the particle (in terms of  $r$  and  $\theta$ ) if it is to execute this motion?

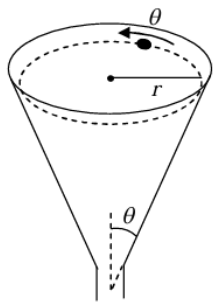

- (a)  $\sqrt{rg \sin \theta}$                       (b)  $\sqrt{rg \cos \theta}$

- (c)  $\sqrt{rg \tan \theta}$                       (d)  $\sqrt{rg \cot \theta}$

18. Two rails of a railroad track are insulated from each other and from the ground, and are connected by a millivoltmeter. What is the reading of the millivoltmeter when a train travels at the speed 90 km/hr down the track? Assume that the vertical component of the earth's magnetic field is 0.2 gauss and that the tracks are separated by two meters. Use 1 gauss =  $10^{-4}$  Tesla =  $10^{-4} V \cdot \text{sec}/\text{m}^2$

- (a) 10                      (b) 1

- (c) 0.2                      (d) 180

19. A particle of mass  $m$  moves in a one-dimensional potential  $V(x) = F_0|x|$ , where  $F_0$

is a positive constant. Given the initial conditions,  $x(0) = x_0 > 0$  and  $\dot{x}(0) = 0$ , which one of the following statements is correct?

(a) The particle undergoes simple harmonic motion about the origin with frequency  $\omega =$

$$2\pi \sqrt{\frac{F_0}{mx_0}}$$

(b) The angular frequency of oscillations of

$$\text{the particle is } \omega = \frac{1}{2} \pi \sqrt{\frac{F_0}{2mx_0}}$$

(c) The particle begins from rest and is accelerated along the positive  $x$ -axis such

$$\text{that } x(t) = \frac{x_0 + F_0 t^2}{2m}$$

(d) The angular frequency of oscillations of the particle is independent of its mass

20. A carbon rod of resistance  $R_c$  and a metal rod of resistance  $R_m$  are connected in series. Let their linear temperature coefficients of resistivity have magnitudes  $\alpha_c$  and  $\alpha_m$ , respectively. The condition that the net resistance would be independent of temperature is

- (a)  $R_c = R_m$                       (b)  $\alpha_c = \alpha_m$   
 (c)  $\frac{R_c}{R_m} = \frac{\alpha_m}{\alpha_c}$                       (d)  $\frac{R_m}{R_c} = \frac{\alpha_m}{\alpha_c}$

21. The 2's complement of 11111111 is

- (a) 00000001                      (b) 00000000  
 (c) 11111111                      (d) 10000000

22. Two tuning forks  $A$  and  $B$  are struck instantaneously to obtain Lissajous figures.

The figures go through a complete cycle in 20 s. Fork  $A$  is loaded with wax, so that the cycle period changes to 10 s. If the frequency of fork  $B$  is 256.10 Hz, what is the frequency of fork  $A$  after loading?

- (a) 256.00 Hz                      (b) 256.05 Hz  
 (c) 256.15 Hz                      (d) 256.20 Hz

23. Consider a classical harmonic oscillator in thermal equilibrium at a temperature  $T$ . If the spring constant is changed to twice its value isothermally, then the amount of work done on

the system is

- (a)  $k_B T \ln 2$       (b)  $k_B T \frac{\ln 2}{2}$   
 (c)  $2k_B T \ln 2$       (d)  $-k_B T \ln 2$

24. The solution of the differential equation  $y'' - 2y' - 3y = e^u$  is given as  $C_1 e^{-t} + C_2 e^{2t} + C_3 e^{3t}$ . The values of the coefficients  $C_1, C_2$  and  $C_3$  are:

- (a)  $C_1, C_2$  and  $C_3$  are arbitrary  
 (b)  $C_1, C_3$  are arbitrary and  $C_2 = \frac{-1}{3}$   
 (c)  $C_2, C_3$  are arbitrary and  $C_1 = \frac{-1}{3}$   
 (d)  $C_1, C_2$  are arbitrary and  $C_3 = \frac{-1}{3}$

25. A free particle of energy  $E$ , characterized by a plane wave of wavelength  $\lambda$  enters a region of constant potential  $-V$  (where  $E > V > 0$ ). Within the region of the potential, the wavelength of the particle is  $\frac{\lambda}{2}$ . The ratio  $\frac{V}{E}$  is:

- (a)  $\frac{-1}{3}$       (b) -3  
 (c) 3      (d)  $\frac{1}{3}$

26. Consider a quantum particle of mass  $m$  moving in a potential

$$V(x, y) = \begin{cases} \frac{1}{2} m \omega^2 (x^2 + y^2), & \text{for } x > 0, y > 0 \\ \infty, & \text{otherwise} \end{cases}$$

what is the degeneracy of the energy state  $9\hbar\omega$ , where  $\omega > 0$  measures the strength of the potential?

- (a) 4      (b) 2  
 (c) 10      (d) 5

27. Consider a particle with total energy  $E$  is oscillating in a potential  $U(x) = A|x|^n$  with  $A > 0$  and  $n > 0$  in one dimension. Which one of the following gives the relation between the time-period of oscillation  $T$  and

the total energy  $E$  :

- (a)  $T \propto E^{1/n-1/2}$       (b)  $T \propto E^0$   
 (c)  $T \propto E^n$       (d)  $T \propto E^{1/n}$

28. A classical gas of  $N$  particles is kept at a temperature  $T$  and is confined to move on a twodimensional surface ( $xy$ -plane). If an external linear force field is applied along the  $x$ -axis, then the partition function of the system will be proportional to

- (a)  $T^N$       (b)  $T^{2N}$   
 (c)  $T^{N/2}$       (d)  $T^{3N/2}$

29. An electromagnetic field is given by

$$\vec{E}(\vec{r}, t) = -\frac{1}{4\pi\epsilon_0} \frac{q}{r^2} \theta(vt - r) \vec{r}, \quad \vec{B}(\vec{r}, t)$$

$$= 0, \text{ where } \theta(x) = \begin{cases} 1 & \text{for } x > 0 \\ 0 & \text{for } x \leq 0 \end{cases}$$

The corresponding charge density  $\rho$  and current density  $\vec{J}$  are given by

- (a)  $\rho = -q\delta^3(\vec{r})\theta(vt - r) + \frac{q}{4\pi r^2} \theta(vt - r); \vec{J} = 0$   
 (b)  $\rho = -q\delta^3(\vec{r})\theta(vt - r); \vec{J} = 0$   
 (c)  $\rho = \frac{q}{4\pi r^2} \delta(vt - r); \vec{J} = \frac{qv}{4\pi r^2} \delta(vt - r) \hat{r}$   
 (d)  $\rho = -q\delta^3(\vec{r})\theta(vt - r) + \frac{q}{4\pi r^2} \delta(vt - r); \vec{J} = \frac{qv}{4\pi r^2} \delta(vt - r) \hat{r}$

30. A particle of mass  $m$  is placed in a potential well  $U(x) = cX^n$ , where  $c$  is a positive constant and  $n$  is an even positive integer. If the particle is in equilibrium at constant temperature, which one of the following relations between average kinetic energy  $\langle K \rangle$  and average potential energy  $\langle U \rangle$  is correct?

- (a)  $\langle K \rangle = \frac{2}{n} \langle U \rangle$       (b)  $\langle K \rangle = \langle U \rangle$   
 (c)  $\langle K \rangle = \frac{n}{2} \langle U \rangle$       (d)  $\langle K \rangle = 2 \langle U \rangle$

31. What is the charge stored on each capacitor  $C_1$  and  $C_2$  in the circuit shown in the given figure?

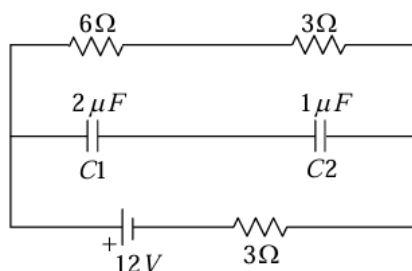

- (a)  $6\mu C, 6\mu C$       (b)  $6\mu C, 3\mu C$   
(c)  $3\mu C, 6\mu C$       (d)  $3\mu C, 3\mu C$

32. A particle moving in two dimensions satisfies the equations of motion

$$\dot{x}(t) = x(t) + y(t)$$

$$\dot{y}(t) = x(t) - y(t)$$

with  $\dot{x}(0) = 0$ . What is the ratio of  $\frac{x(\infty)}{y(\infty)}$ ?

- (a)  $1 - \frac{1}{\sqrt{2}}$       (b)  $1 + \frac{1}{\sqrt{2}}$   
(c)  $\sqrt{2} - 1$       (d)  $\sqrt{2} + 1$

33. Analyse the common emitter transistor circuit given in the figure. If the current gain ( $\beta$ ) increases by 50%, the relative change in collector current ( $I_C$ ) is approximately

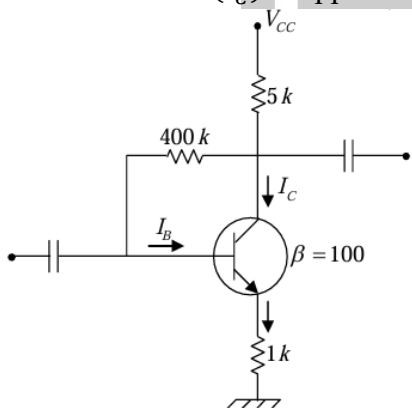

- (a) 5%      (b) 15%  
(c) 20%      (d) 25%

34. What is the value of the following contour integral  $I$  taken counterclockwise around the circle  $|z| = 2$ ?

$$I = \oint_C \frac{dz}{z^3(z+4)}$$

- (a)  $\frac{\pi i}{2}$       (b)  $\frac{\pi i}{32}$   
(c)  $\frac{\pi i}{16}$       (d)  $\frac{\pi i}{4}$

35. Consider a cube (see figure) of volume  $V$  containing  $N$  molecules each of mass  $m$  with uniform density  $n = \frac{N}{V}$ . Suppose this system is equivalent to a system of  $M$  non-interacting gases such that molecules of the  $i$ th gas are  $N_i = n_i V$  in number, each with an identical  $y$  component of velocity  $v_i$ . What is the pressure  $P$  on the surface  $\square ABCD$  of area  $A$ ?

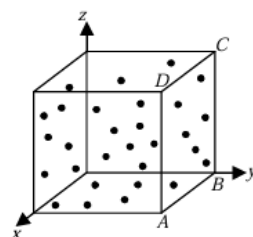

- (a)  $P = m \sum_{i=1}^M n_i v_i^2$   
(b)  $P = \frac{m \sum_{i=1}^M n_i v_i^2}{\sum_{i=1}^M n_i}$   
(c)  $P = \frac{m \sum_{i=1}^M n_i v_i^2}{2}$   
(d)  $P = 2m \sum_{i=1}^M n_i v_i^2$

36. The wave function of a particle subjected to a spherically symmetric potential  $V(r)$  is given by  $\psi(\vec{r}) = (x - y + 2z)f(r)$ . Which one of the following statements is true about  $\psi(\vec{r})$ ?

- (a) It is an eigenfunction of  $\vec{L}^2$  with  $l = 0$   
(b) It is an eigenfunction of  $\vec{L}^2$  with  $l = 1$   
(c) It is an eigenfunction of  $\vec{L}^2$  with  $l = 2$   
(d) It is not an eigenfunction of  $\vec{L}^2$

37. The Hamiltonian for a particle of mass  $m$  is given by  $H = \frac{(p - \alpha q)^2}{(2m)}$ , where  $\alpha$  is a non-zero constant. Which one of the following

equations is correct?

(a)  $p = m\dot{q}$       (b)  $\alpha\dot{p} = \dot{q}$

(c)  $\ddot{q} = 0$       (d)  $L = \frac{1}{2}m\dot{q}^2 - \alpha q\dot{q}$

38. A continuous He – Ne laser beam ( $\lambda = 632.8 \text{ nm}$ ) is 'chopped', using a spinning aperture into  $1\mu\text{s}$  square pulses. The order-of-magnitude estimate of the spectral width  $\Delta\lambda$  of the emerging 'pulsed' light is

(a)  $10^{-9} \text{ m}$       (b)  $10^{-12} \text{ m}$

(c)  $10^{-15} \text{ m}$       (d)  $10^{-18} \text{ m}$

39. The Hamiltonian of a classical particle is

given by  $H(p, q) = \frac{p^2}{2m} + \frac{kq^2}{2}$ . Given

$F(p, q, t) = \ln(p + im\omega q) - i\alpha\omega t$  is a

constant of motion (where  $\omega = \sqrt{\frac{k}{m}}$ ). What is

the value of  $\alpha$  ?

(a)  $2\pi$       (b) 0

(c) 1      (d)  $\pi$

40. Three polarizers are stacked, normal to a central axis, along which is incident a beam of unpolarized light of intensity  $I_0$ . The first and the third polarizers are perpendicular to each other and the middle polarizer is rotated at an angular frequency  $\omega$  about the central axis (light beam). The time dependent intensity of light emerging after the third polarizer will be given by

(a)  $I(t) = \left(\frac{I_0}{16}\right) \{1 - \cos(4\omega t)\}$

(b)  $I(t) = \left(\frac{I_0}{8}\right) \{1 - \cos(2\omega t)\}$

(c)  $I(t) = \left(\frac{I_0}{4}\right) \{1 - 2\cos \omega t\}$

(d)  $I(t) = \left(\frac{I_0}{2}\right) \cos^2 \omega t$

41. A thin film of water having refractive index  $n = 1.333$  floats on the surface of a beaker of

silicone oil having refractive index  $n_s = 1.40$ . The arrangement is illuminated by  $600 \text{ nm}$  light incident normally from top and a large region of the film appears bright red. What is the minimum possible thickness of the film (in nm) ?

42. What is the value of the following integral?

$$I = \frac{100\sqrt{2}}{\pi} \int_0^{\pi/2} x \delta(2\sin x - \sqrt{2}) dx$$

43. Two compartments in a cylinder with uniform cross section and total length  $102 \text{ cm}$  are separated by a sliding partition which can move but does not allow heat to pass across it. No molecules are present in either of the compartments. The radiation inside each compartment is in thermal equilibrium with its walls. The walls at the two ends of the cylinder are maintained at temperatures  $2000 \text{ K}$  and  $4000 \text{ K}$ , respectively. The sides are perfectly insulated. Find the location of the partition, measured from the left end of the container.

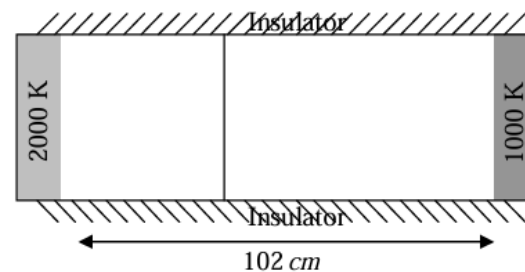

44. A laser has output power of  $150 \text{ mW}$  with beam diameter of  $2 \text{ mm}$  at a wavelength  $630 \text{ nm}$ . What is the value of the electric field in units of  $V/m$  is? Use Coulomb's constant,  $\frac{1}{(4\pi\epsilon_0)} = 9 \times 10^9 \text{ Nm}^2\text{C}^{-2}$

45. A two-state quantum system has energy eigenvalues  $\pm\epsilon$  corresponding to normalised states  $\psi_{\pm}$ . At time  $t = 0$  the system is in the quantum state  $\frac{[\psi_{+} + \psi_{-}]}{\sqrt{2}}$ . Find the  $10000 \times$  probability that the system will be in the same

state at time  $t = \frac{h}{(6\epsilon)}$ , where  $h$  is the Planck's constant.

46. A small insect of mass  $m$  is sitting on the rim of a uniform circular horizontal disk of radius  $R$  and mass  $M$ . The system is rotating at a constant angular velocity  $\omega_i$  about a frictionless vertical axis passing through the center of the disk. The insect started to crawl towards the center of the disk. Assume  $\frac{M}{m} = 10$ , and let the final angular velocity of the system, when the insect reaches the centre of the disk be  $\omega_f$ . What is the value of  $\frac{100\omega_f}{\omega_i}$  ?

47. A particle is moving on a one-dimensional discrete lattice with lattice spacing unity. It can move from a site to its nearest neighbour site every  $1/5$  seconds with  $p$  being the probability to move right and  $q = (1 - p)$  being the probability to move left. Consider that the particle starts at origin,  $x = 0$  at time  $t = 0$ . Taking  $p = \frac{3}{4}$ , calculate the variance  $\langle(x - \langle x \rangle)^2\rangle$  at time  $t = 5 \times 10^4$  seconds, where  $\langle x \rangle$  is the average position.

48. Analyse the op-amp circuit shown in the figure below. What is the output voltage ( $V_0$ ) in millivolts if  $V_1 = 2.5$  and  $V_2 = 2.25$  V ?

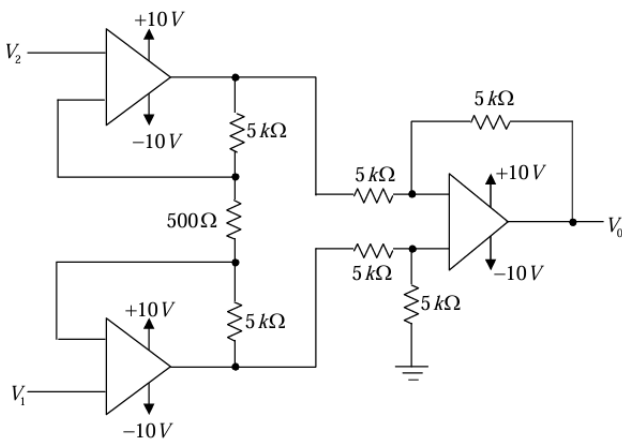

49. Some bacteria are added to a bucket at time 10am. The number of bacteria doubles every minute and reaches a number  $16 \times 10^{15}$  at

10: 18am. How many seconds after 10 am were there  $25 \times 10^{13}$  bacteria?

50. A cleaning machine presses a circular mop of radius  $R = 30$  cm vertically down on a floor with a total force  $F = 25$  N and rotates it with a constant angular speed about the vertical axis passing through the centre of mop. If the force is distributed uniformly over the mop and if the coefficient of friction between the mop and the floor is  $\mu = 0.25$ , what is the value of torque in  $N - \text{cm}$  applied by the machine on the mop?

### Answer Key

1. a	2. b	3. d	4. c	5. b
6. b	7. d	8. d	9. b	10. a
11. a	12. c	13. b	14. c	15. d
16. b	17. d	18. b	19. b	20. c
21. a	22. a	23. b	24. b	25. c
26. a	27. a	28. d	29. d	30. c
31. a	32. d	33. b	34. b	35. a
36. b	37. c	38. c	39. c	40. a
41. 0.225	42. 0.025	43. 0.0006	44. 6000	45. 2500
46. 0.120	47. 46875	48. 5305	49. 0.720	50. 0.125